

Vision Lentis

High Performance Bench Magnifier for inspection, manipulation and material rework

Bench magnifiers are typically used for:
illuminated inspection of small parts...
or manipulation and rework (cutting, soldering,
welding, polishing and painting).

Traditional bench magnifiers suffer from:

- Instability
- Optical distortion (often at the edge of the image)
- Reflection disturbance (from ambient light)
- Inadequate illumination

Lentis is a state of the art magnifier, designed to incorporate the optical, ergonomic and mechanical design excellence adopted throughout Vision Engineering's range of award winning stereo microscopes, measuring systems and optical aids.



Technical Data

Optical Data		
Viewing Lens	Working Distance	Field of View
2.5 dioptres	80 - 250mm	250mm

Lighting Data	
True colour optimised fluorescent tubes. Ultraviolet (UV) option available	
2 x 4W with double reflectors	2,000 hours

Accessories
Dust cover Replacement 4W fluorescent (White & UV)

Features and Benefits

- High specification optical lens for minimal distortion across the entire field of view. The lens is finished with a multi-layer anti-reflective coating to minimise ambient reflection disturbance.

Ease of Use

- 2.5 dioptre lens provides optimal magnification, field of view and working distance for optimum comfort.
- Long life, ultra bright, reflected fluorescent illumination for superb image clarity and colour rendition.

Versatility

- Ultra modern stand design with quick move base for high stability and versatility.



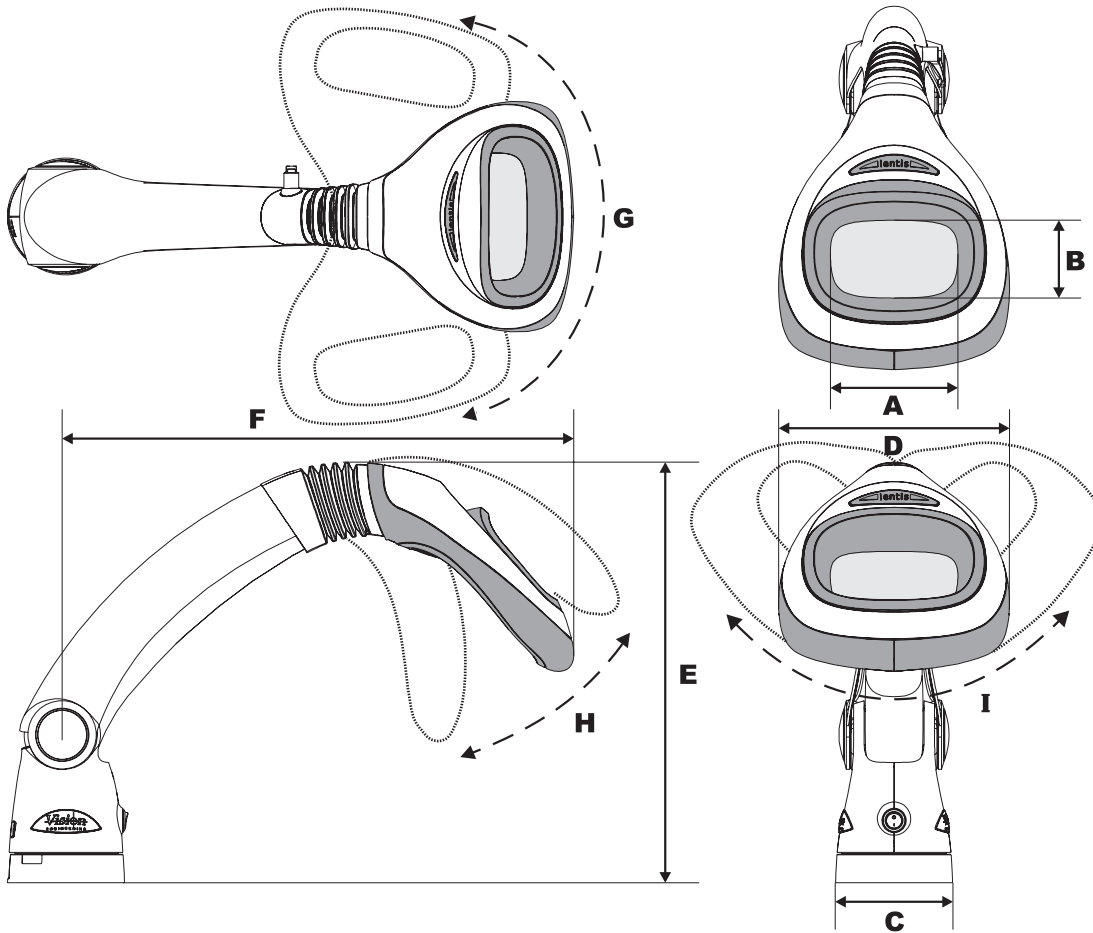

Dimensions

A = 134mm
 B = 82mm
 C = 132mm
 D = 240mm

Height

E = 290mm - 540mm

Reach

F = 460mm - 640mm

G = Yaw

80° - 160°

H = Viewing angle

65° - 20°

I = Roll

22.5° - 45°

Unpacked weight

Head & Stand = 4.0kg

Packed weight

Head & Stand = 6.0kg

Power Supply

All Lentis units are powered with a wall plug socket transformer, available in all worldwide plug configurations and delivering 9V DC to the Lentis illuminator in the optical head or stand.

For more information...

Vision Engineering has a network of offices and technical distributors around the world. Please contact your Vision Engineering branch, local authorised distributor, or visit our website.

Vision Engineering Ltd.
 (Manufacturing)
 Send Road, Send, Woking,
 Surrey, GU23 7ER, England
 Tel: +44 (0) 1483 248300
 Fax: +44 (0) 1483 223297
 Email: generalinfo@visioneng.com

Vision Engineering Inc.
 (Manufacturing & Commercial)
 570 Danbury Road, New Milford,
 CT 06776 USA
 Tel: +1 (860) 355 3776
 Fax: +1 (860) 355 0712
 Email: info@visioneng.com

Vision Engineering Ltd.
 (Central Europe)
 Anton Pendle Strasse 3,
 D-82275, Emmering, Germany
 Tel: +49 (0) 8141 40167-0
 Fax: +49 (0) 8141 40167-55
 Email: info@visioneng.de

Vision Engineering Ltd.
 (France)
 1 Rue de Terre Neuve, ZA Courtaboeuf,
 91967 Les Ulis Cedex, France
 Tel: +33 (0) 164 46 90 82
 Fax: +33 (0) 164 46 31 54
 Email: info@visioneng.fr

Vision Engineering Ltd.
 (Commercial)
 Monument House, Monument Way West,
 Woking, Surrey, GU21 5EN, England
 Tel: +44 (0) 1483 248300
 Fax: +44 (0) 1483 248301
 Email: generalinfo@visioneng.com

Vision Engineering Inc.
 (Commercial West Coast USA)
 745 West Taft Avenue, Orange,
 CA 92865 USA
 Tel: +1 (714) 974 6966
 Fax: +1 (714) 974 7266
 Email: info@visioneng.com

Nippon Vision Engineering
 (Japan)
 272-2 Saedo-cho, Tsuduki-ku,
 Yokohama-shi, 224-0054, Japan
 Tel: +81 (0) 45 935 1117
 Fax: +81 (0) 45 935 1177
 Email: info@visioneng.jp

Vision Engineering Ltd.
 (Italy)
 Via Cesare Cantù, 9
 20092 Cinisello Balsamo MI, Italy
 Tel: +39 02 6129 3518
 Fax: +39 02 6129 3526
 Email: info@visioneng.it



Visit our multi-lingual website:
www.visioneng.com

Distributor